

---

**DRF7020D20**  
**20dBm ISM RF Transceiver Module**

**V1.30**

---

**Features**

- GFSK transceiver Module
- 433Mhz ISM frequency band
- 19.2K bps data rate
- Multiple channels
- 20dBm Max. output power
- Baud rate configurable
- 256 bytes data buffer
- Standby current < 5uA
- Supply voltage 3.4~5.5V

**Application**

- Home automation
- Security alarm
- Telemetry
- Automatic meter reading
- Contactless access
- Wireless data logger
- Remote motor control
- Wireless sensor network

**DESCRIPTION**

DRF7020D20 is a low-cost sub-1 GHz transceiver module designed for operations in the unlicensed ISM (Industrial Scientific Medical) and LPRD bands. GFSK (Frequency Shift Keying) modulation/demodulation, multi-channel operation, high bandwidth efficiency and anti-blocking performance make DRF7020D20 modules easy to realize the robust and reliable wireless link.

The module can be configured to work in different channels with 200k Hz space. It adopts high efficient looped interleaving EDAC (Error Detection and correction) coding with coding gain up to 3dB which keeps in advance in EDAC and coding efficiency over normal FEC (Forward Error Correction). Because of its high reliability in correction, modules can filter error and fake information automatically and realize truly transparent wireless link, which makes DRF7020D20 very suitable in the rigid communication environment.

DRF7020D20 integrates 256 bytes buffer. When the buffer is empty, users can transfer 256 bytes data per time and even limitless data transfer can be achieved as long as RF data rate (RF module to RF module) is configured to be faster than UART data rate (MCU to RF module). The module provides standard UART/TTL interface for selection. Users can choose seven data rates and three parity checks which make DRF7020D20 possibly tailor-made for different applications.

DRF7020D20 operates at 3.3~5.5V with extra low standby current which makes it suitable for battery powered-up applications.

**PIN FUNCTIONS**

PIN	Name	Function	Description
1	GND	Ground	Ground (0V)
2	VCC	Power	Power supply
3	EN	Input	Enable pin (>1.6V);
4	RXD	Input	UART input, TTL level
5	TXD	Output	UART output, TTL level
6	AUX	Output	Data In/Out indication
7	SET	Input	Parameter setting pin, Low: effective

**Table 1 DRF7020D20 Pin functions**

**ELECTRICAL SPECIFICATIONS**

Symbol	Parameter (condition)	Min.	Typ.	Max.	Units
VCC	Supply Voltage	3.4		5.5	V
Temp	Operating temperature range	-30	25	85	°C
RH	Operating relative humidity	10		90	%
Freq	Frequency range	418		455	MHz
F <sub>DEV</sub>	Modulation deviation		28.8		KHz
Mod	Modulation type		GFSK		
I <sub>DD</sub>	Receive mode			32	mA
	Transmit mode @ 20dBm			100	mA
	Sleep mode			5	uA
P <sub>out</sub>	Output power			20	dBm
Sen	Receiving sensitivity @9.6K bps		-117		dBm
DR <sub>FSK</sub>	GFSK data rate	2.4	9.6	19.2	Kbps
DR <sub>IN</sub>	Interface data rate	1.2		57.6	Kbps
T <sub>s</sub>	Switching time		5		us
CH <sub>BW</sub>	Channel spacing		200		kHz
Z <sub>ANT</sub>	Antenna Impedance		50		Ohm

**Table 2 DRF7020D20 Electrical Specifications**

**ABSOLUTE MAXIMUM RATINGS**

Symbol	Parameter	Min.	Max.	Units
VCC	Supply Voltage	-0.3	5.5	V
VI	Input voltage	-0.3	VCC+0.3	V
VO	Output voltage	-0.3	VCC+0.3	V
TST	Storage temperature	-55	125	°C

**Table 3 DRF7020D20 Maximum Ratings**

**Setting Parameters**

**1. Default Values**

Parameter	Option	Default Value	Unit
MCU data rate	1.2, 2.4, 4.8, 9.6, 19.2, 38.4, 57.6	9.6	Kbps
Parity Check	No check, Even parity, Odd parity	No check	
Frequency	418MHz ~ 455MHz (1KHz per step)	433.92	MHz
GFSK data rate	2.4, 4.8, 9.6, 19.2	9.6	Kbps
Output Power	0 ~ 9 levels	9 (20dBm)	

**Table 4 DRF7020D20 Default Settings**

**2. Parameter Setting**

Users can configure the parameters (frequency, data rate, output power, etc.) of RF modules by PC or MCU.

- ◆ **BY PC.** The interface of DRF7020D20 is UART/TTL. If connecting it to PC, users need to use a TTL-to-RS232 level converter to transform the different levels. Dorji Applied Technologies also provides converter board for configuration.

Firstly users need to insert module into converter board and connect converter board to PC by cable, then open DORJI RF software. After that the status column of tool should display “Found Device”. Users then can read/write the module. For more details, please check the operation manuals of converter boards on accessory page.

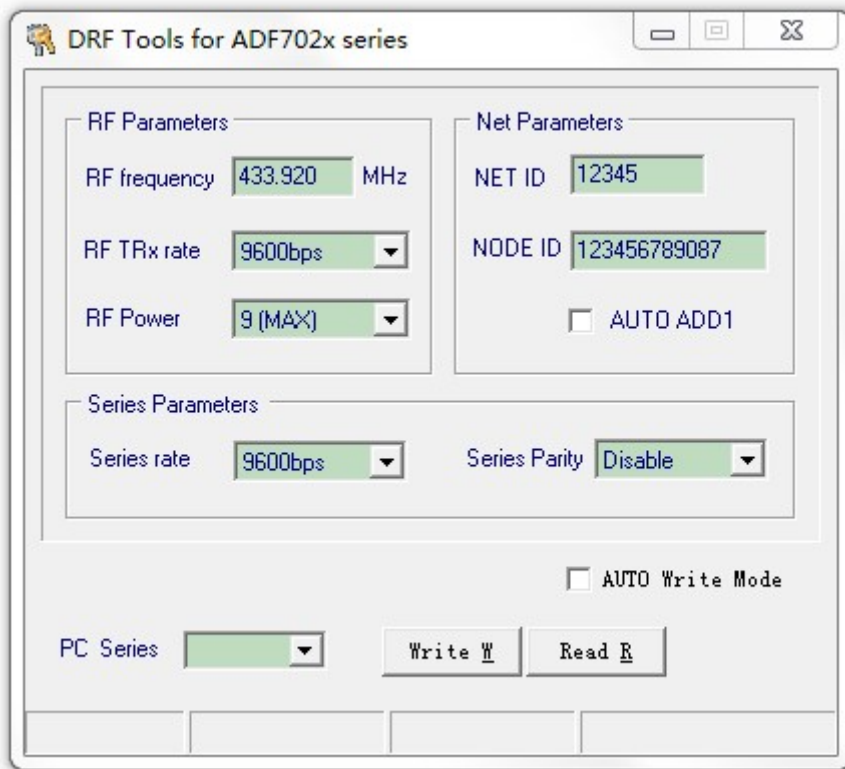

**Figure 1: DORJI RF TOOL**

- ◆ **BY MCU.** The module can work normally 50ms (T1) after powering on. When configuring the module, users need to switch the SET pin to low and the module then enters into setting mode after 1mS or more (T2). It will use 9600 bps (data rate) and no parity check as default format to communicate.

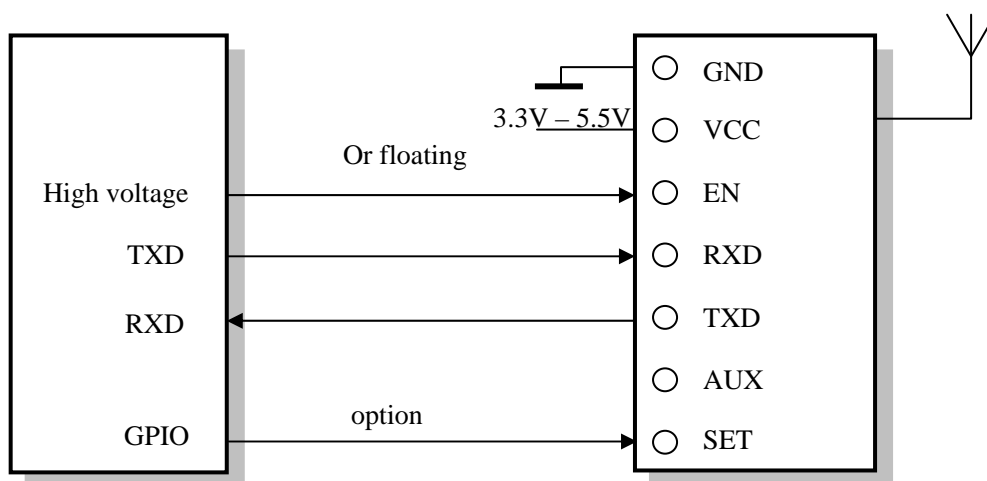
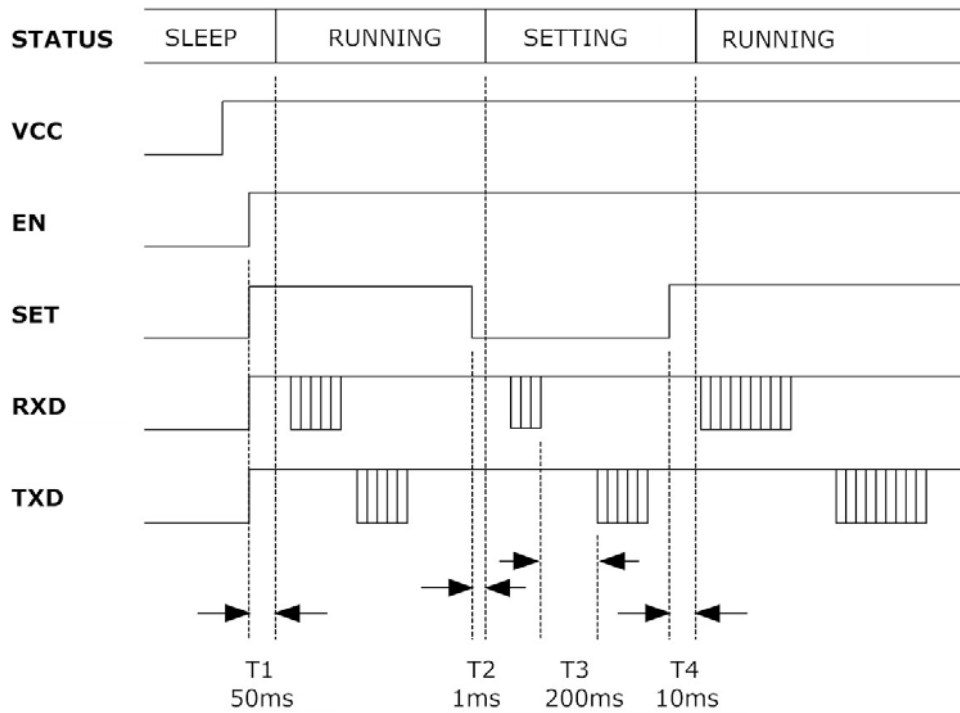

**Figure 2: Connecting Diagram**

When a command is sent to the module through the RXD pin, the module will send back

response information by TXD pin in 200mS after it verifies the command is correct. When users check out the parameters are successfully set from the response information, the SET pin can be set to high and the module will work with the new settings in 10mS (T4).

Please note that users only can send command once when the SET pin is configured to low. If users want to revise the parameters after a successful setting, users must configure SET pin to high and then set it into low in order to reconfigure the module. After 100ms (T4), the module will work with the new parameters. P



**Figure 3: Timing Sequence for Setting Parameters**

The commands of DRF7020D20 are ASCII coding. The default configuring data rate is 9600 bps and no parity check included. The command set include two commands: Read command and Write command.

- ◆ **Read command:** RD ✓  
*Response (from module):* PARA\_Freq\_DR<sub>FSK</sub>\_P<sub>OUT</sub>\_DR<sub>IN</sub>\_Parity ✓
- ◆ **Write command:** WR\_Freq\_DR<sub>FSK</sub>\_P<sub>OUT</sub>\_DR<sub>IN</sub>\_Parity ✓  
*Response (from module):* PARA\_Freq\_DR<sub>FSK</sub>\_P<sub>OUT</sub>\_DR<sub>IN</sub>\_Parity ✓

Parameter	Unit	Length(Bytes)	Explanation
Freq.	KHz	6	433.92MHz = 433920
DR <sub>FSK</sub>	Kbps	1	2400, 4800, 9600, 19200 bps equal to 1, 2,

			3, 4
P <sub>OUT</sub>	dB	1	0~9; 0 refers to -1dBm and 9 for 20dBm
DR <sub>IN</sub>	Kbps	1	1.2, 2.4, 4.8, 9.6, 19.2, 38.4, 57.6 equal to 0, 1, 2, 3, 4, 5, 6
Parity		1	0: No parity; 1: Even parity; 2: Odd parity

**Table 5 DRF7020D20 Parameter Coding**

E.g. If the user wants to set the module work at Freq (433.92MHz), DR<sub>FSK</sub> (9.6k bps), P<sub>OUT</sub> (20 dBm), DR<sub>IN</sub> (1.2K bps) and Parity (no parity), the command could be written as below:

**Write Command:** WR\_433920\_3\_9\_0\_0 ✓

*Corresponding HEX code:* 0x57,0x52,0x20,0x34,0x33,0x33,0x39,0x32,0x30,0x20,0x33,0x20,0x39,0x20,0x30,0x20,0x30,0x0D,0x0A ✓

**Response:** PARA\_433920\_3\_9\_0\_0 ✓

*Corresponding HEX code:* 0x50,0x41,0x52,0x41,0x20,0x34,0x33,0x33,0x39,0x32,0x30,0x20,0x33,0x20,0x39,0x20,0x30,0x20,0x30,0x0D,0x0A ✓

## Application Notes

DRF7020D20 series are half-duplex wireless modules which can be used in point-to-point or point-to-multi point applications. In the latter application, users need to set one module as the host and others as client modules. Each module must have a unique ID and the coordination of communication is controlled by the host which send data and commands including ID. If the client module finds that the ID contained in the received message is the same as its own, it will continue to receive the remaining data; otherwise it will discard the coming message. In order to avoid any interference, only one module is allowed to work in transmitting mode at any time.

**Mechanical Data**

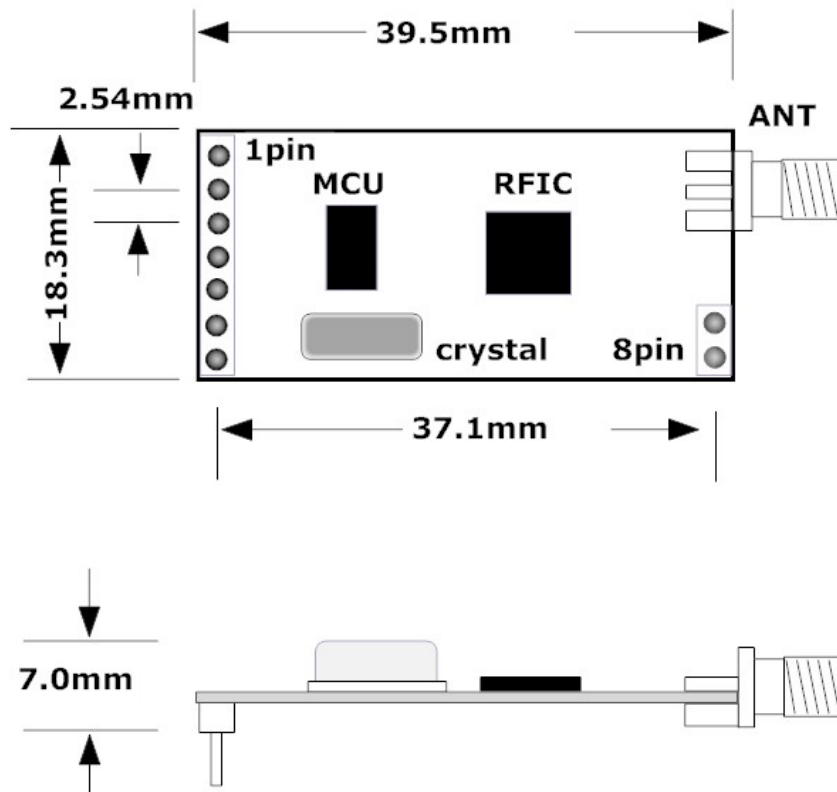

Figure 4: Mechanical dimension

**Ordering Information**

**DRF 7020 D 20 — 043 A**

- ① ② ③ ④ ⑤ ⑥

Num	Symbol	Meaning
①	RF module	RF GFSK module
②	IC Type	ADF7020
③	Module Function	Data transmission
④	Power	20dBm output power
⑤	Freq. Band	043: 433MHz
⑥	Package	DIP package with SMA connector

Table 6 Ordering information

<p>Dorji Applied Technologies A division of <i>Dorji Industrial Group Co., Ltd</i></p> <p>Add.: Xinchenuayuan 2, Dalangnanlu, Longhua, Baoan district, Shenzhen, China 518109</p> <p>Tel: 0086-755-28156122 Fax.: 0086-755-28156133 Email: <a href="mailto:sales@dorji.com">sales@dorji.com</a> Web: <a href="http://www.dorji.com">http://www.dorji.com</a></p>	<p>Dorji Industrial Group Co., Ltd reserves the right to make corrections, modifications, improvements and other changes to its products and services at any time and to discontinue any product or service without notice. Customers are expected to visit websites for getting newest product information before placing orders.</p> <p>These products are not designed for use in life support appliances, devices or other products where malfunction of these products might result in personal injury. Customers using these products in such applications do so at their own risk and agree to fully indemnify Dorji Industrial Group for any damages resulting from improper use.</p>
--	---